

ENGLISH COMPREHENSION: Sample Questions

All questions are Multiple-Choice-Questions with only one option as the correct answer.

In the following question select the word which is OPPOSITE in the meaning of the given word.

Q1. INDISCREET

- a. reliable
- b. honest
- c. prudent
- d. stupid

Q2. SOLICITUDE

- a. insouciance
- b. ingenuity
- c. propriety
- d. austerity

Q3. In the sentence there is a bold word or phrase. One of the words or phrases given in the options conveys almost the same meaning as the bold word or phrase in the sentence. Select that option which is nearest in meaning.

It is **preposterous** on your part to look for a job without first completing your education.

- a. Wise
- b. Imperative
- c. Advisable
- d. Most admirable
- e. Very absurd

In the following questiones, fill in the blank space.

Q4. The success that he has gained, though striking enough, does not, however, commensurate the efforts made by him.

- a. About
- b. From
- c. With
- d. Beside
- e. Over

Q5. Vinod took his meals after he

- a. Had completed his work
- b. Had been completing his work
- c. Was completing his work
- d. Had been completed his work
- e. Had got completed his work

In the following questions, select the word or phrase that is similar in meaning to the given word.

Q6. Nonchalance

- a. Neutrality
- b. Indifference
- c. All-knowing
- d. Ignorance

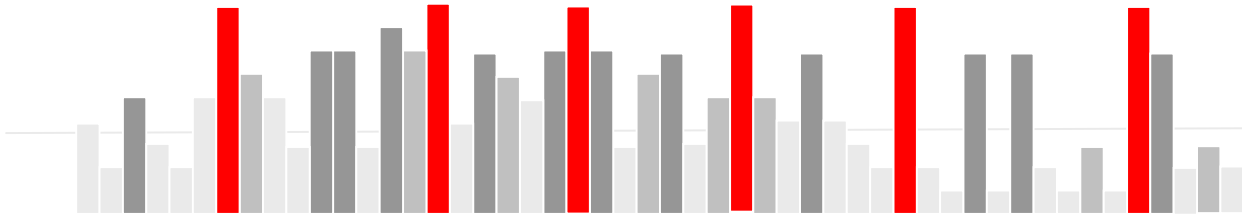

e. Untimeliness

Q7. Conceal

- a. Hide
- b. Seal
- c. Ceiling
- d. Horrifying

Q8. Read the sentence to find out whether there is any grammatical error in it. The error, if any, will be in one part of the sentence. The letter of that part is the answer. If there is no error, the answer is 'D'. (Ignore - the errors of punctuation, if any)

(A) The whole thing moves/ (B) around the concept of building a small dynamic/(C) organisation into a larger one./ (D) No error.

- a. (A)
- b. (B)
- c. (C)
- d. (D)

Q9. In the question a part of the sentence is italicised. Alternatives to the italicised part is given which may improve the sentence. Choose the correct alternative. In case no improvement is needed. Option 'D' is the answer.

She *gave* most of her time to music.

- a. spent
- b. lent
- c. devoted
- d. No improvement

Q10. The given sentences when properly sequenced, form a coherent paragraph. Each sentence is labelled with a number. Choose the most logical order of sentences from among the four given choices to construct a coherent paragraph.

1. He was so busy with them that he did not get time to eat. 2. Thousands of people came to him and asked different types of questions. 3. No one cared to see that he had his food or rest that night. 4. Swami Vivekanand once stayed in a small village.

- a. 2341
- b. 3214
- c. 4213
- d. 4231

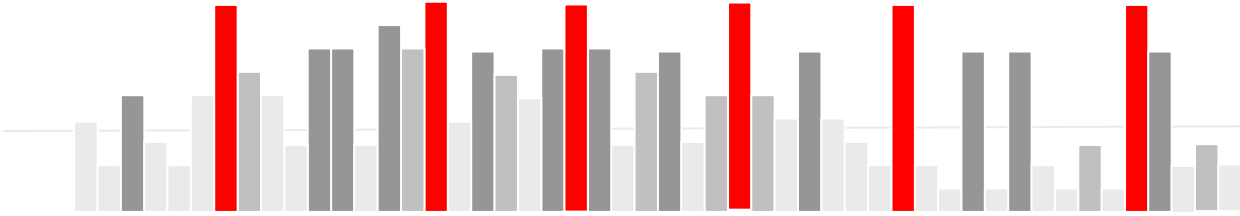

Answer the question based on the given passage

Management is a set of processes that can keep a complicated system of people and technology running smoothly. The most important aspects of management include planning, budgeting, organising, staffing, controlling, and problem-solving. Leadership is a set of processes that creates organisations in the first place or adapts them to significantly changing circumstances. Leadership defines what the future should look like, aligns people with that vision, and inspires them to make it happen despite the obstacles. This distinction is absolutely crucial for our purposes here: Successful transformation is 70 to 90 per cent leadership and only 10 to 30 percent management. Yet for historical reasons, many organisations today don't have much leadership. And almost everyone thinks about the problem here as one of managing change. For most of this country, as we created thousands and thousands of large organisations for the first time in human history, we didn't have enough good managers to keep all those bureaucracies functioning. So many companies and universities developed management programs and hundreds and thousands of people were encouraged to learn management on the job. And they did. But, people were taught little about leadership. To some degree, management was emphasised because it's easier to teach than leadership. But even more so, management was the main item on the twentieth-century agenda because that's what was needed. For every entrepreneur or business builder who was a leader, we needed hundreds of managers to run their ever-growing enterprises. Unfortunately for us today, this emphasis on management has often been institutionalised in corporate cultures that discourage employees from learning how to lead. Ironically, past success is usually the key ingredient in producing this outcome. The syndrome, as I have observed it on many occasions, goes like this: success creates some degree of marked dominance which in turn produces much growth. After a while keeping the ever-larger organisation under control becomes the primary challenge. So attention turns inward and managerial competencies are nurtured. With a strong emphasis on management but not leadership, bureaucracy and an inward focus takeover. But with continued success, the result mostly of market dominance, the problem often goes unaddressed and an unhealthy arrogance begins to evolve. All of these characteristics then make any transformation effort much more difficult. Arrogant managers can over-evaluate their current performance and competitive position, listen poorly and learn slowly. Inwardly focused employees can have difficulty seeing the very forces that present threats and opportunities. Bureaucratic cultures can smother those who want to respond to shifting conditions. And the lack of leadership leaves no force inside these organisations to break out of the morass.

Q11. Why did companies and universities develop programmes to prepare managers in such a large number?

- (A) Companies and universities wanted to generate funds through these programmes
- (B) The large number of organisations were created as they needed managers in good number
- (C) Organisations did not want to spend their scarce resources in training managers
- (D) Organisations wanted to create communication network through trained managers

Q12. How has the author defined management?

- It is the process of adapting organisations to changing circumstances.
- It is the system of aligning people with the direction it has taken.
- It refers to creating a vision to help direct the change effectively.
- Creating better performance through customer orientation.

Q13. What is the historical reason for many organisations not having leadership?

- A view that leaders are born, they are not made
- Leaders lack managerial skills and organisations need managers
- Leaders are weak in carrying out traditional functions of management
- Leaders allow too much complacency in organisations

Q14. Which of the following characteristics help organisations in their transformation efforts?

- Emphasis on leadership but not management
- A strong and dogmatic culture
- Bureaucratic and inward looking approach

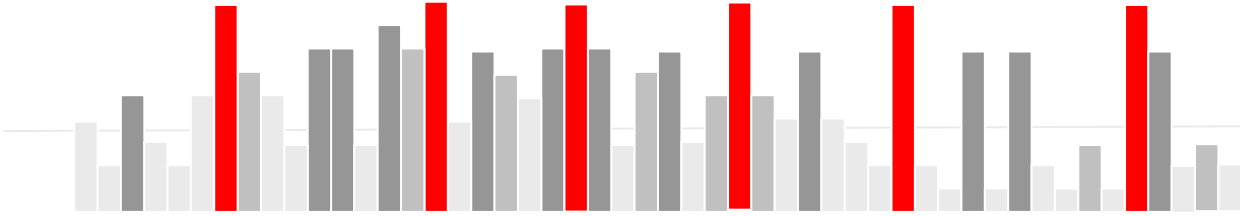

d. Failing to acknowledge the value of customers and shareholders

Q15. Which of the following is similar in meaning of the word 'smother' as used in the passage?

- a. Suppress
- b. Encourage
- c. Instigate
- d. Criticise

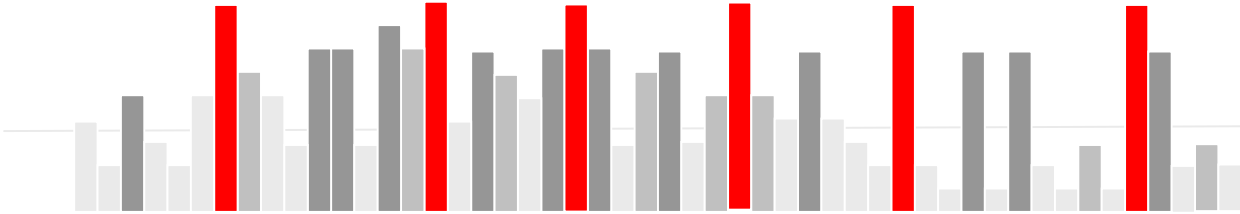

QUANTITATIVE ABILITY: Sample Questions

All questions are Multiple-Choice-Questions with only one option as the correct answer.

Q1. In a kilometre race, if A gives B a 40 m start, A wins by 19 s. But if A gives B a 30 s start, B wins by 40 m. Find the time taken by B to run 5,000 m?

- a. 150 s
- b. 450 s
- c. 750 s
- d. 825 s

Q2. Pipe A takes 16 min to fill a tank. Pipes B and C, whose cross-sectional circumferences are in the ratio 2:3, fill another tank twice as big as the first. If A has a cross-sectional circumference that is one-third of C, how long will it take for B and C to fill the second tank? (Assume the rate at which water flows through a unit cross-sectional area is same for all the three pipes.)

- a. 66/13
- b. 40/13
- c. 16/13
- d. 32/13

Q3. Three consecutive whole numbers are such that the square of the middle number is greater than the product of the other two by 1. Find the middle number.

- a. 6
- b. 18
- c. 12
- d. All of these

Q4. The arithmetic mean of 2 numbers is 34 and their geometric mean is 16. One of the numbers will be

- a. 4
- b. 16
- c. 18
- d. 12

Q5. If $x\%$ of a is the same as $y\%$ of b , then $z\%$ of b is :

- a. $(xy/z)\%$ of a
- b. $(yz/x)\%$ of a
- c. $(xz/y)\%$ of a
- d. None of these

Q6. The letters of the word WOMAN are written in all possible orders and these words are written out as in a dictionary, then the rank of the word 'WOMAN' is

- a. 117
- b. 120
- c. 118
- d. 119

Q7. What least number must be subtracted from 9400 to get a number exactly divisible by 65?

- a. 40
- b. 20
- c. 80

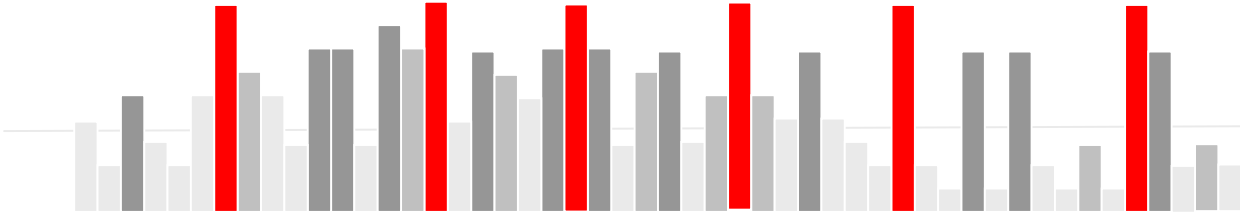

d. none of these

Q8. If $2505 / 0.5 = 5010$ then $25.05 / 0.5 = ?$

- a. 5.010
- b. 50.10
- c. 501.0
- d. None of these

Q9. Which pair of rational numbers lie between $1/5$ and $2/5$ -

- a. $262/1000, 275/1000$
- b. $362/1000, 562/1000$
- c. $451/1000, 552/1000$
- d. $121/1000, 131/1000$

Q10. What is the value of the following expression: $2 \log_{10} 5 + \log_{10} 4$?

- a. 2
- b. 2.5
- c. 3
- d. None of these

Q11. If x increases linearly, how will a^{-x} behave ($a > 1$) ?

- a. Increase linearly
- b. Decrease linearly
- c. Increase exponentially
- d. Decrease exponentially

Q12. What is the probability of getting the sum 5 in two throws of the dice?

- a. $1/12$
- b. $1/5$
- c. $1/9$
- d. None of these

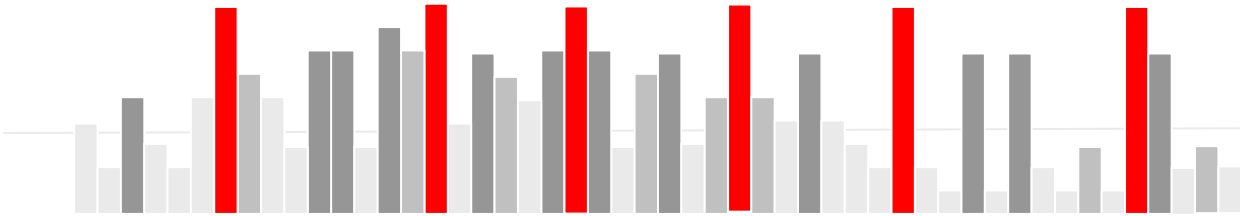

LOGICAL ABILITY: Sample Questions

All questions are Multiple-Choice-Questions with only one option as the correct answer.

Q1. The question shows a pair of words in which the first is related to the second in some way. It is followed by a single word which bears a similar relation to one of the given alternatives. Find the correct alternative to complete the analogy.

Melt:Liquid::Freeze: ?

- a. Ice
- b. Condense
- c. Solid
- d. Crystal

Q2. Fill in the blank Guilt is to Past as Hope is to

- a. Present
- b. Future
- c. Today
- d. Despair
- e. Hopeless

Q3. From the given choices select the odd man out:

- a. Bird
- b. Kite
- c. Crow
- d. Pigeon
- e. Sparrow

Q4. Find the missing pattern

BOQD : ERTG :: ANPC : ?

- a. DQSF
- b. FSHU
- c. SHFU
- d. DSQF

Q5. Find the missing number

5 : 24 :: 8 : ?

- a. 65
- b. 63
- c. 62
- d. 64

Q6. From the given choices select the odd man out

- a. DFHEG
- b. TWXUV
- c. OQSPR
- d. JLNKM

Q7. If HARD is coded as 1357 and SOFT is coded as 2468, what will 21448 stand for?

- a. SHAFT

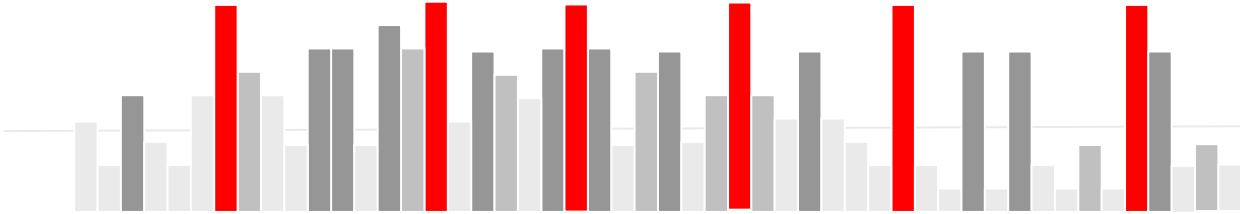

- b. SHORT
- c. SHOOT
- d. SHART

Q8. Find the next number in the series

1, 6, 13, 22, 33,

- a. 44
- b. 45
- c. 46
- d. 47

Q9. The question contains some statements followed by some conclusions. Decide which of the given conclusions logically follow from the given statements, disregarding commonly known facts.

Statements:

- I) All tomatoes are red.
- II) All grapes are tomatoes.

Conclusions:

- I) All grapes are red.
- II) Some Tomatoes are grapes.

- a. Only conclusion I follows.
- b. Only conclusion II follows.
- c. Neither I nor II follows
- d. Both I and II follow.
- e. Either I or II follows

Q9. Old woman's son is my daughter's uncle, then what relation has the old woman to me ?

- a. Sister
- b. Mother
- c. Grandmother
- d. Mother - in - law

Q10. Ramu was facing East.He walked 4 km forward and then after turning to his right walked 6 km. Again he turned to his right and walked 7 km. After this he turned back.Which direction was he facing at the time?

- a. East
- b. North
- c. South
- d. West
- e. North-East

Q11. Raman is not wearing purple and Aman is not wearing black.Raman and Sahil wear different colours.Avinash alone wears green.What is Sahil's colour, if all four of them are wearing different colours.

- a. Green
- b. Black
- c. Purple
- d. Can't Say

Q12. The question is followed by two arguments numbered I and II. You have to decide which of the arguments is a strong argument and which is a weak argument.

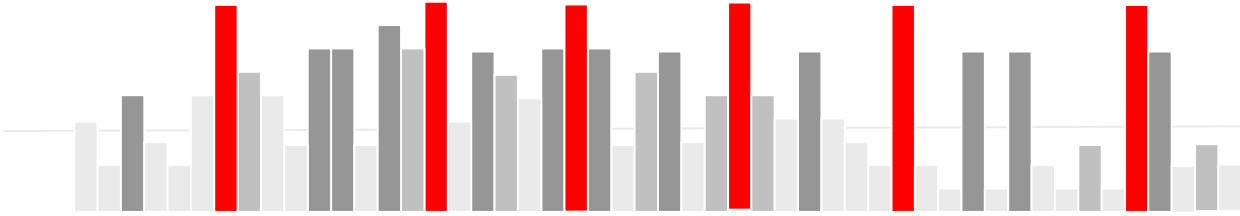

Statement :

Should a total ban be put on trapping wild animals?

Arguments :

- I. Yes, Trappers are making a lot of money.
- II. No, bans on hunting and trapping are not effective.

- a. Only argument I is strong.
- b. Only argument II is strong.
- c. Either I or II is strong.
- d. Neither I nor II is strong.
- e. Both I and II are strong

Q13. The question contains a statement followed by two Assumptions I and II. Find out which assumption(s) is implicit.

Statements:

Vitamin E tablets improve circulation, keep your complexion in glowing condition.

Assumptions :

- I. People like glowing complexion.
- II. Complexion becomes dull in the absence of circulation.

- a. Only assumption I is implicit
- b. Only assumption II is implicit
- c. Both assumption I and II are implicit.
- d. Neither assumption I nor II is implicit

Q14. Study the statement(s) and the conclusions and select the correct option.

Statement :

No country is absolutely self - dependent these days.

Conclusions :

- I. It is imposible to grow and produce all that a country needs.
- II. Countrymen in general have become lazy.

- a. Only Conclusion I follows
- b. Only Conclusion II follows
- c. Both the conclusion I and II follow
- d. Either conclusion I or II follows
- e. Neither conclusion I nor II follows

Q15. In the question a statement is followed by some courses of action . A course of action is a step or administrative decisions to be taken for improvement, follow-up, or further action in regard to the problem, policy, etc. You have to assume everything in the statement to be true and then decide which of the given suggested course(s) of action logically follows for pursuing.

Statement:

"The World Bank has approved a \$ 300 million loan to finance a project to construct coal ports by Madras Port Trusts.

Courses of Action :

- I. India should take financial help from other international financial institutions to develop such ports in other places.
- II. India should not seek any help from the international financial institutions.

- a. Only I follows
- b. Only II follows
- c. Either I or II follows
- d. Neither I nor II follows
- e. Both I and II follow.

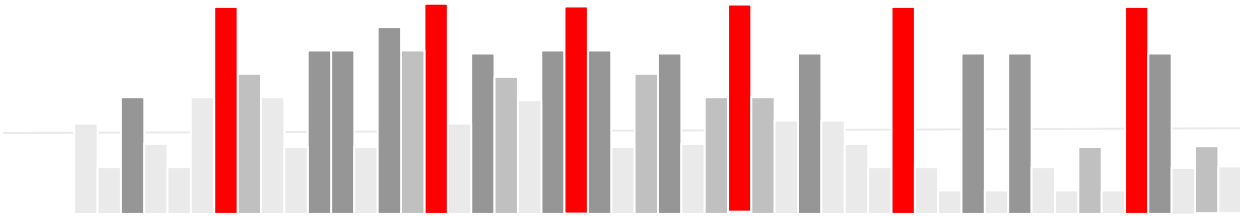

COMPUTER PROGRAMMING PRINCIPLES AND APPLICATIONS: Sample Questions

All questions are Multiple-Choice-Questions with only one option as the correct answer.

Q1. A 8-bit signed integer has the following range:

- a. 0 to 255
- b. -128 to 127
- c. -255 to 254
- d. 0 to 509

Q2. What will be the output of the following code statements?

```
integer x = 34.54, y = 20, z = -5
print ( y > 50 AND z > 10 or x > 30 )
```

- a. 0
- b. 1
- c. -1
- d. 10

Q3. Pankaj makes a program to print the product of cubes of the first 10 whole numbers. She writes the following program:

```
integer x = 0 // statement 1
integer sum = 0 // statement 2
while ( x < 10 ) // statement 3
{
    sum = x*x*x // statement 4
    x = x + 1 // statement 5
}
print sum // statement 6
```

Is her program correct? If not, which statement will you modify to correct it?

- a. No error, the program is correct.
- b. Statement 1
- c. Statement 4
- d. statement 6

Q4. I have a problem to solve which takes as input a number n. The problem has a property that given the solution for (n-1), I can easily solve the problem for n. Which programming technique will I use to solve such a problem?

- a. Iteration
- b. Decision-making
- c. Object Oriented Programming
- d. Recursion

Q5. Given:

```
integer x = 40, y = 35, z = 20, w = 10
```

Comment about the output of the following two statements:

```
print x * y / z - w
print x * y / (z - w)
```

- a. Differ by 80

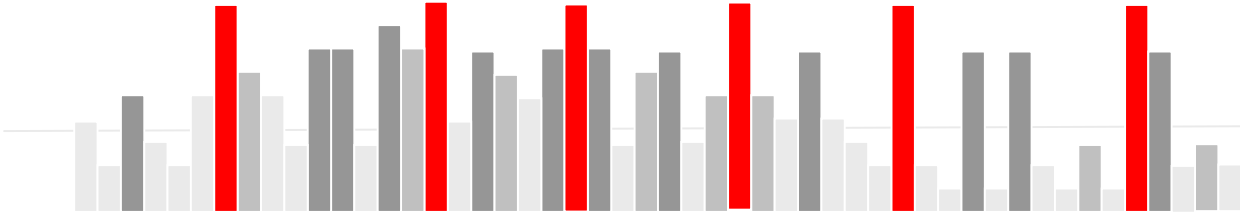

- b. Same
- c. Differ by 50
- d. Differ by 160

Q6. Data and function in which area of a class are directly accessible outside the class?

- a. Public
- b. Private
- c. Protected
- d. None of these

Q7. Here is an infix notation: $((A+B)*C-(D-E))^{(F+G)}$ Choose the correct postfix notation of the above from the given options.

- a. $AB+CD^*E--FG+^{\wedge}$
- b. $AB+C^*DE--FG+^{\wedge}$
- c. $AB+C^*DE-FG-+^{\wedge}$
- d. $A+BC^*DE-FG-+^{\wedge}$

Q8. If the depth of a tree is 3 levels, then what is the size of the Tree?

- a. 2
- b. 4
- c. 6
- d. 8

Q9. One of the following options is a form of access used to add and remove nodes from a queue.

- a. LIFO
- b. FIFO
- c. Both LIFO and FIFO
- d. None of these

Q10. What is the time complexity of adding three matrices of size $N \times N$ cell-by-cell?

- a. $O(N)$
- b. $O(N^2)$
- c. $O(N^3)$
- d. None of these

Electronic: Sample Questions

All questions are Multiple-Choice-Questions with only one option as the correct answer.

Q 1. The input resistance of the inverter shown below is

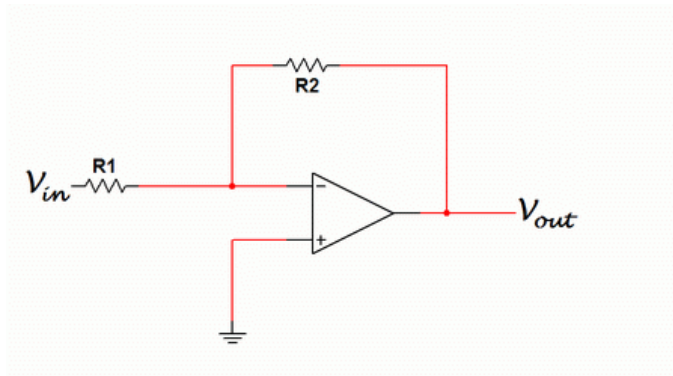

- a. R_1
- b. $R_1 + R_2$
- c. $R_1 || R_2$
- d. R_2

Q 2. Find the equivalent capacitance of the system shown in the figure between points a and b.

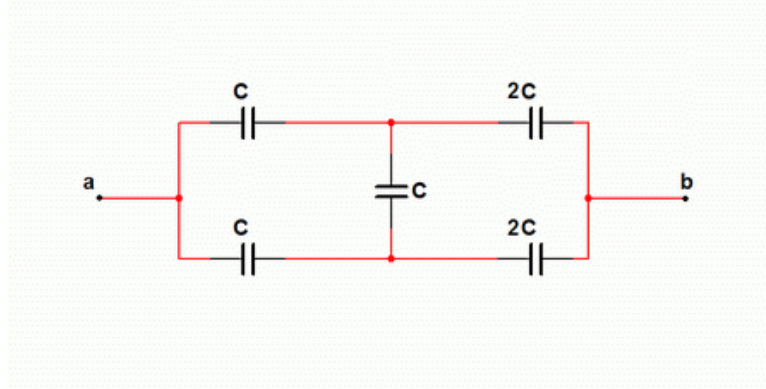

- a. $2C$
- b. $2C/3$
- c. $4C/3$
- d. C

Q3. The Boolean function F is given by -

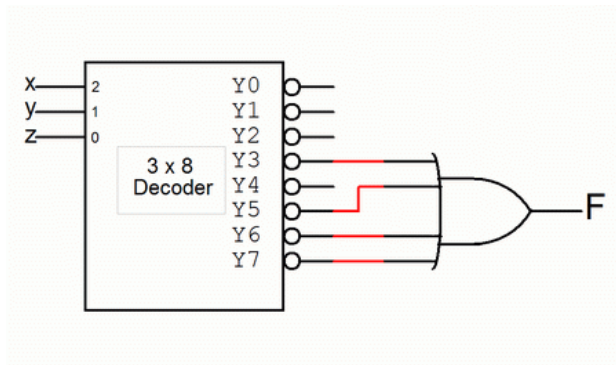
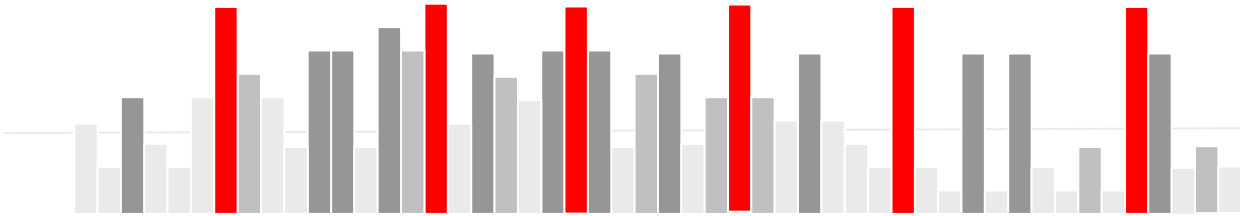

- a. $xyz + xy' + xz'$
- b. $xy + yz + xz$
- c. $yz + xy' + xz'$
- d. $xyz + xy' + x'z$

Q 4 The small signal gain of the circuit shown is given by:

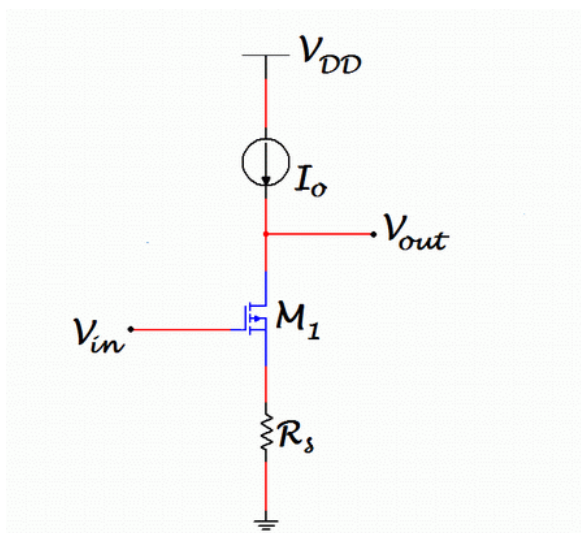

- a. $-g_m r_o$
- b. $-g_m r_o / (1 + g_m R_s)$
- c. $-g_m (r_o || R_s)$
- d. $-g_m r_o / (R_s + r_o + g_m r_o R_s)$

Q 5. Which logic function is realized by the given circuit.

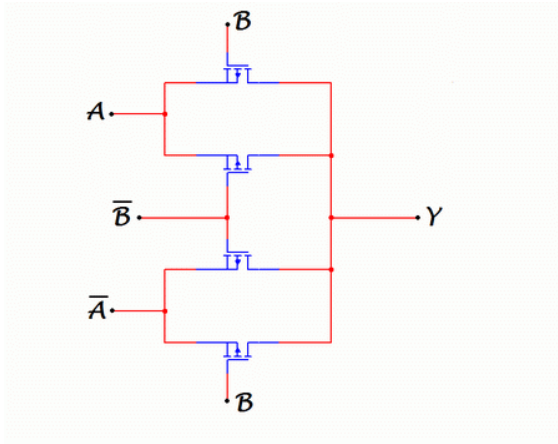
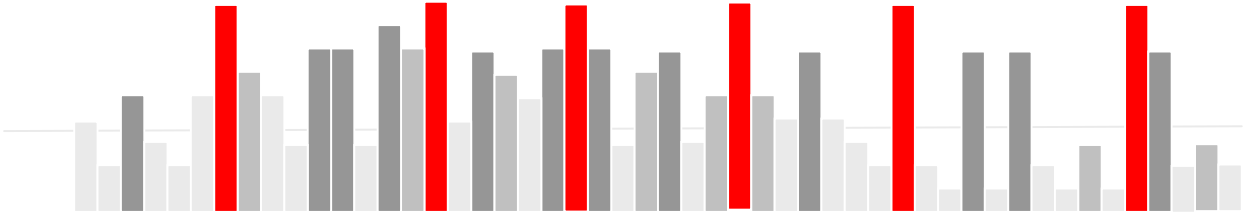

- a. NOR
- b. XOR
- c. XNOR
- d. None of these

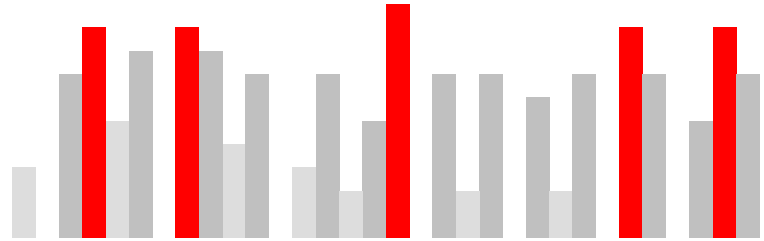

Mechanical : Sample Questions

All questions are Multiple-Choice-Questions with only one option as the correct answer.

1) How much weight is required to balance the lever?

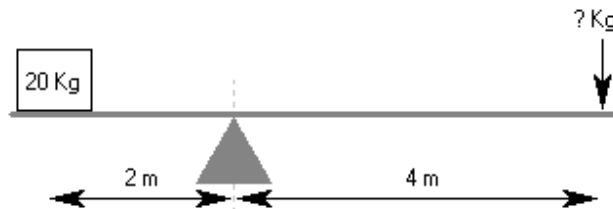

- A** 15Kg **B** 5Kg **C** 10Kg **D** 7.5Kg **E** 20Kg

Hint: the force required in the following way: $w \times d1 = f \times d2$

Where:
 w = weight
 d1 = distance from fulcrum to weight
 f = force needed
 d2 = distance from fulcrum to point where force is applied

2) Approximately how much force is needed to lift the weight?

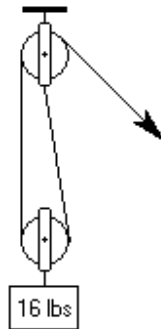

- A** 9 lbs **B** 8 lbs **C** 6 lbs **D** 4 lbs **E** 16 lbs

Hint: If the pulley is fixed, then the force required is equal to the weight. If the pulley moves with the weight then the force is equal to half of the weight. Another way of thinking about this is to divide the weight by the number of sections of rope supporting it to obtain the force needed to lift it.

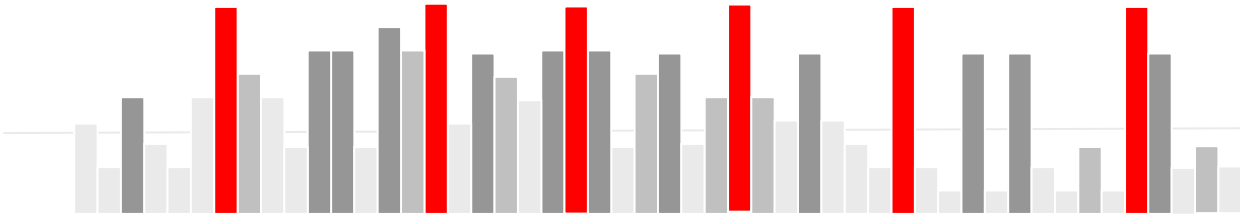

3) If gear X turns clockwise at a constant speed of 10 rpm. How does gear Y turn?



- A** anti c/w 10 rpm **B** c/w 10 rpm **C** c/w 5 rpm **D** anti c/w 5 rpm **E** c/w 20 rpm

Hint: When gears are touching (meshed) then adjacent gears move in opposite directions. In this example the first and third gear will turn in the same direction. When there are an odd number of meshed gears then the last gear will always turn in the same direction as the first one. The rate at which the gears turn is directly proportional to the number of teeth on each gear, with the smaller gear turning faster.

4) If drive wheel X rotates clockwise at a speed of 10 rpm. How does wheel Y turn?

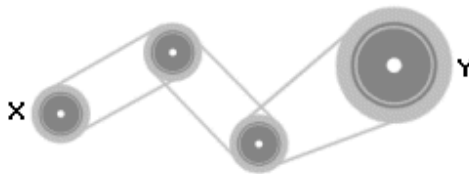

- A** anti c/w faster **B** c/w slower **C** c/w faster **D** anti c/w slower **E** anti c/w same

Hint: Where pulley wheels are driven by belts, they rotate in the same direction. Smaller wheels will turn faster than larger wheels.

5) A force of 15 Kg compresses the parallel in series 10cm. What will be the total distance that the springs in series are compressed?

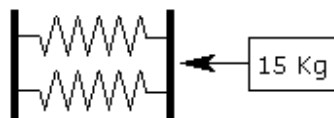

- A** **B** **C** **D** **E**

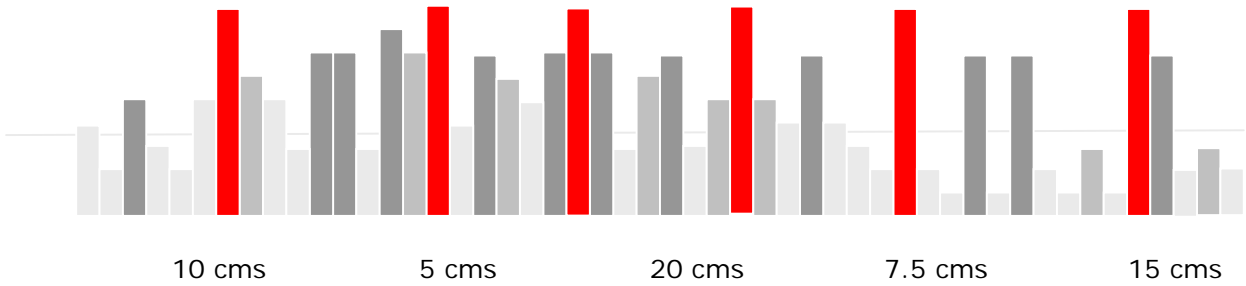

Hint: When springs are arranged in series, each spring is subjected to the force applied. When the springs are arranged in parallel the force is divided equally between the springs.

6) If bulb 1 is removed, how many bulbs will light up when the switch is closed?

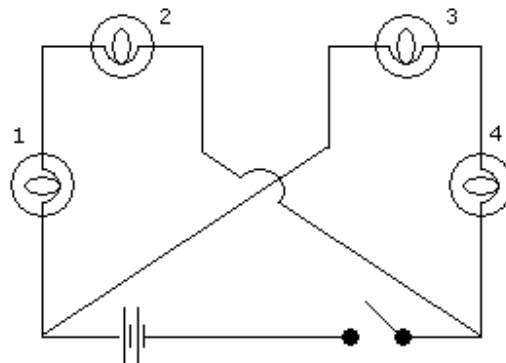

- A** None **B** One **C** Two **D** Three **E** Four

Hint: These diagrams are usually restricted to showing the power source, switches, loads (typically bulbs), and the path of the wiring. To answer these questions you need a basic understanding of how electricity flows around a circuit.

7) Which is the most suitable tool for general carpentry?

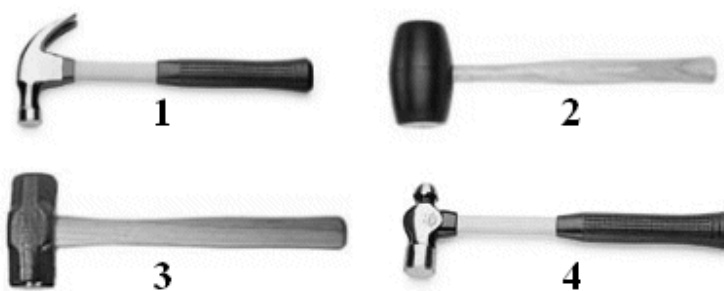

- A** None **B** 1 **C** 2 **D** 3 **E** 4

Hint: Whilst all of the tools shown could be used, one of them is designed specifically for the job.

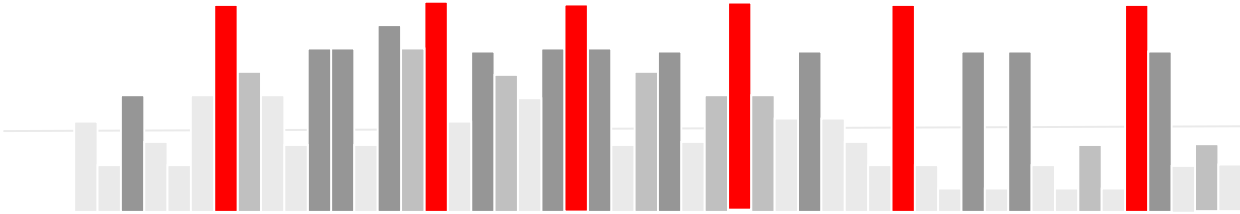

8) Which tool or combination of tools would be most useful for constructing a mild steel frame?



A
3 & 4

B
9

C
1 & 9

D
2 & 8

E
6

Hint: If you don't have much practical experience of making and fixing things then you will need to make some effort to improve your knowledge of everyday tools. You can do this by getting hold of a catalog for a tool hire company and simply reading through it.

The sketch shows a component which is stamped out of sheet steel. These components are stamped out of a continuous steel coil with a width of 75 cms. The stamping process requires a gap of 25mm between each component. The steel is supplied in lengths of 30 meters costing \$200.

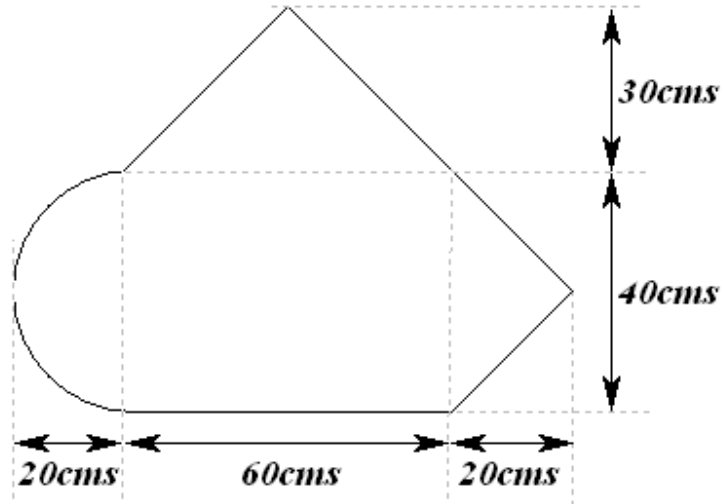
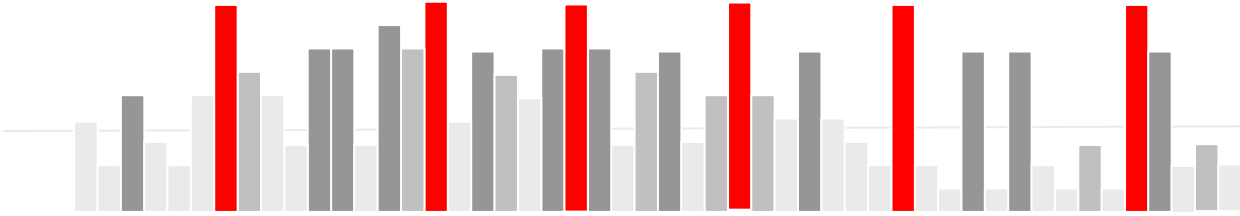

9) What is the approximate area of the component in square centimetres?

- | | | | | |
|----------|----------|----------|----------|----------|
| A | B | C | D | E |
| 4688 | 4470 | 4562 | 4860 | 4328 |

10) What is the approximate percentage of steel wasted?

- | | | | | |
|----------|----------|----------|----------|----------|
| A | B | C | D | E |
| 42% | 35% | 44% | 37% | 39% |

Hint: Some questions may require you to know some simple formulas. For example, the areas of simple shapes like rectangles, circles and triangles.